

Pocket Door Fitting Instructions

Single Door

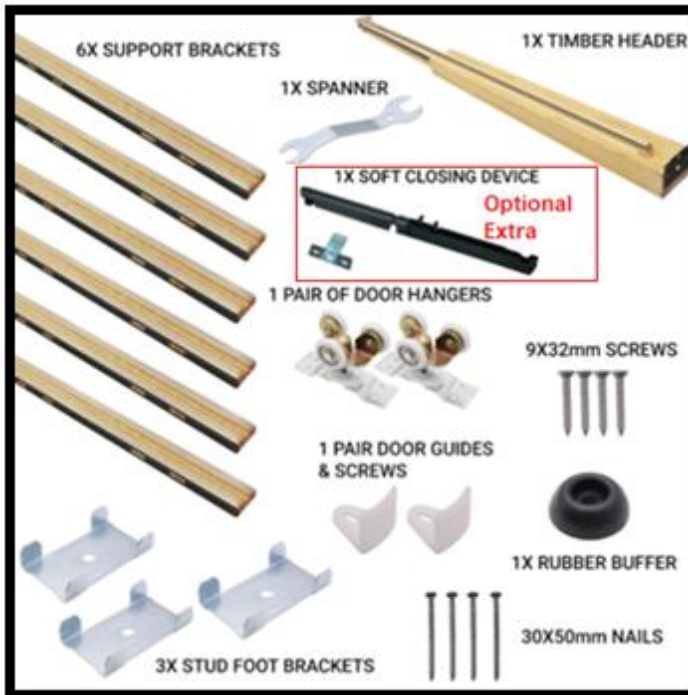

Double Door

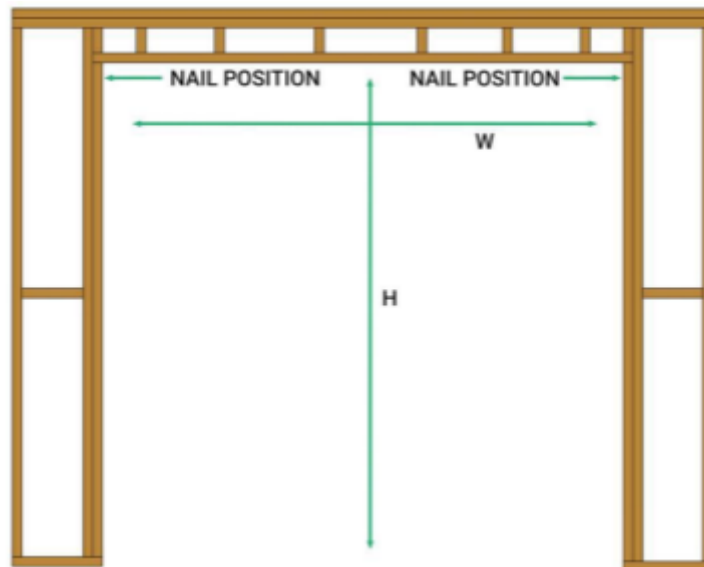
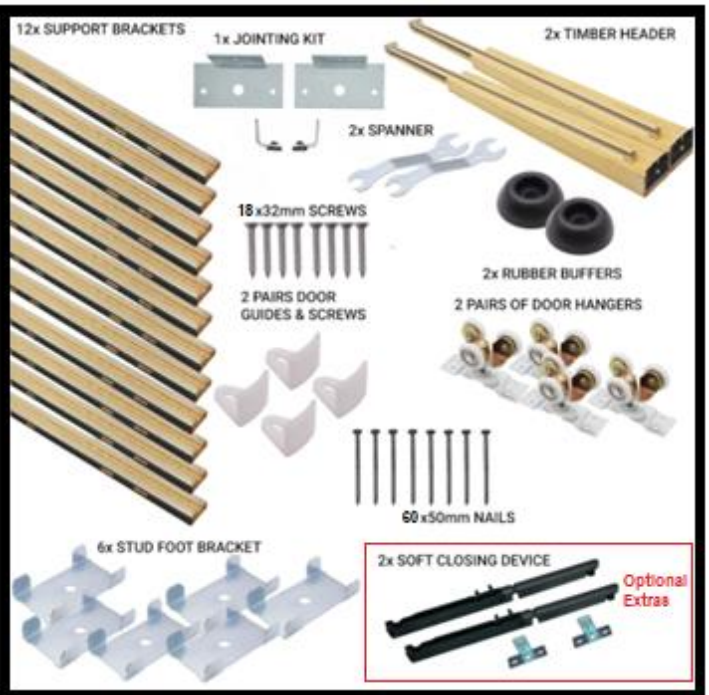

Step 1 : Create The Wall Opening

Single door

$H = \text{Door Height} + 114\text{mm}$

$W = \text{Door width} \times 2 + 25\text{mm}$

$\text{Nail Position} = \text{Door height} + 38\text{mm}$

Double Door

$H = \text{Door Height} + 164\text{mm}$

$W = \text{Door width} \times 4 + 50\text{mm}$

$\text{Nail Position} = \text{Door height} + 38\text{mm}$

- Construct the rough opening and insert the header nails at door height plus 38mm, (leave enough of the nail exposed to hook the header onto).
- The measurements are based on the structural floor, giving a 30mm gap under the door for the finished flooring (carpet, wood floor etc.) to be fitted. To adjust the gap to 20mm, the opening height would be door height + 104mm for a single door kit, or door height + 154mm for a double door kit, the nail positions door height + 28mm.

Step 2 : Prepare Timber Header Unit

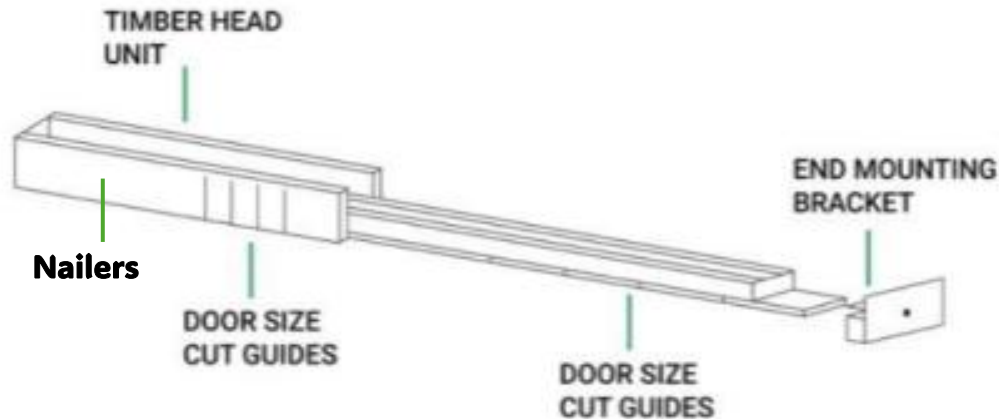

The header unit is pre-marked for door sizes:

PDK915 – 608mm (2'), 712mm (2'4"), 762mm (2'6") and 813mm (2'8") the full header length is 915mm.

PDK1200 – 915mm (3'), 1016mm (3'4"), 1067mm (3'6") and 1118mm (3'8") the full header length is 1219mm



- To cut down the header, find the appropriate marks on either side of the header on the nailers (section has timber on both sides), and on the top surface of the header.
- Mark the door size where the nailers are to be cut and the top/track are to be cut.
- Remove the bracket on the end of the header with no nailers.
- The distance between the marks is doubled on the top of the header (distance between 2 foot 6 inches and 2 foot 8 inches is 4 inches not 2 inches). The measurement must allow for the required overall track length (twice door width + 25mm)
- If you are using a custom (unmarked) door size you must allow for this.
- Cut down the nailers on both sides and remove the excess carefully from the header
- Cut the top face and the track down.
- Cut an additional 38mm (1.5 inches) off the track, the mounting bracket can then be reattached.

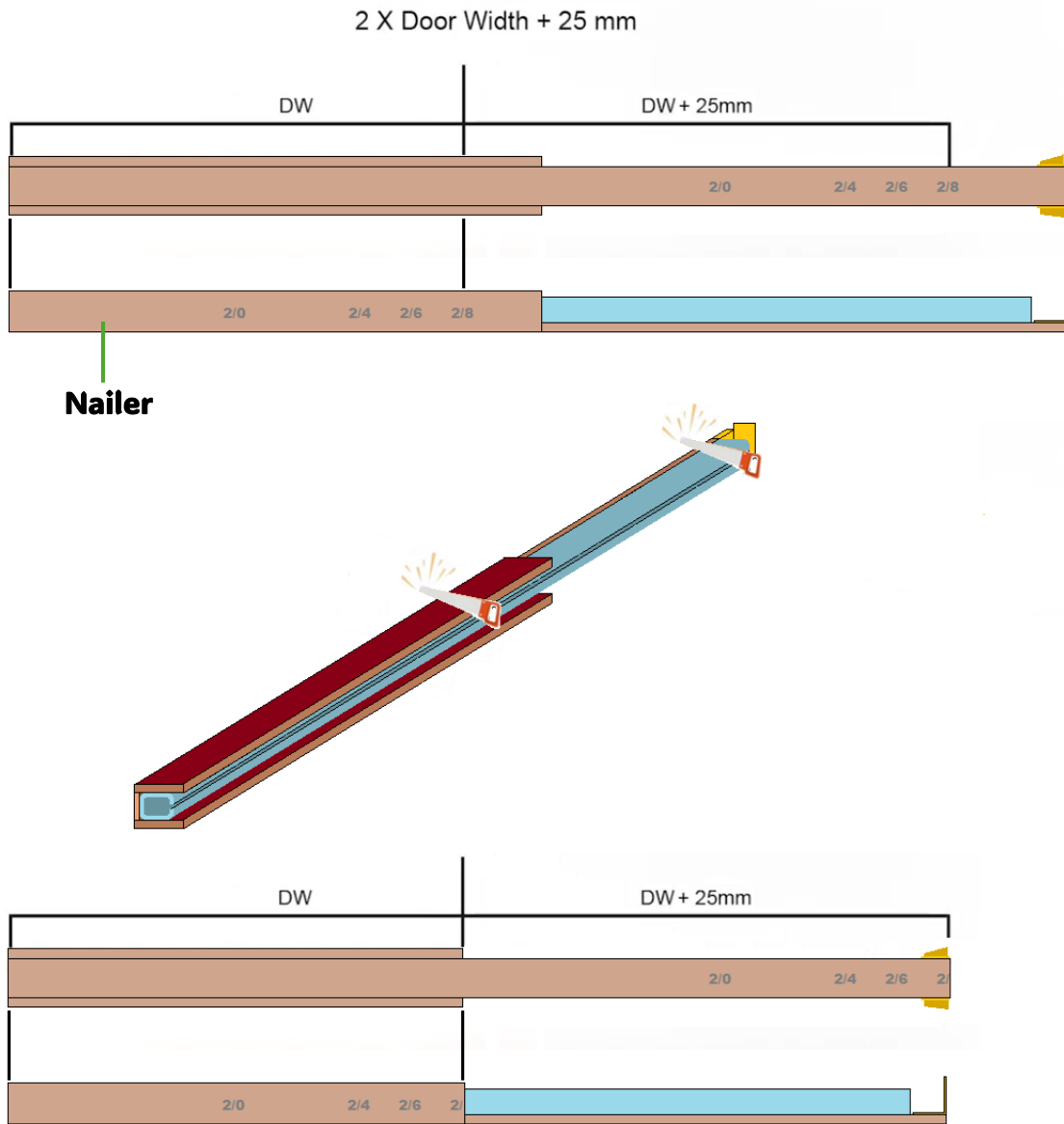

Step 3 : Installing the Header Track Single Door

Position the header with the nailers above the door opening position (left image below - single door), for double doors the nailers are positioned in the centre of the opening and bolted together with the jointing kit (right image below – double doors).

Hooking the end plates over the support nails.

Level the header, insert the support nails into the side timbers, drive in the remaining nails through the plates ensuring the header is kept level.

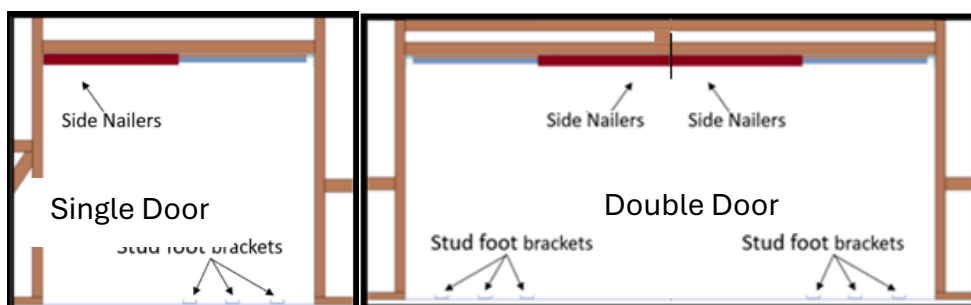

Step 3a : Installing the Header Track Double Doors



- Join the 2 single headers together at the nailer end using the pocket door jointing kit (kit contains 2 fixing plates, 2 door stops, relevant fixings)
- Remove the original end brackets from both headers (door opening end)

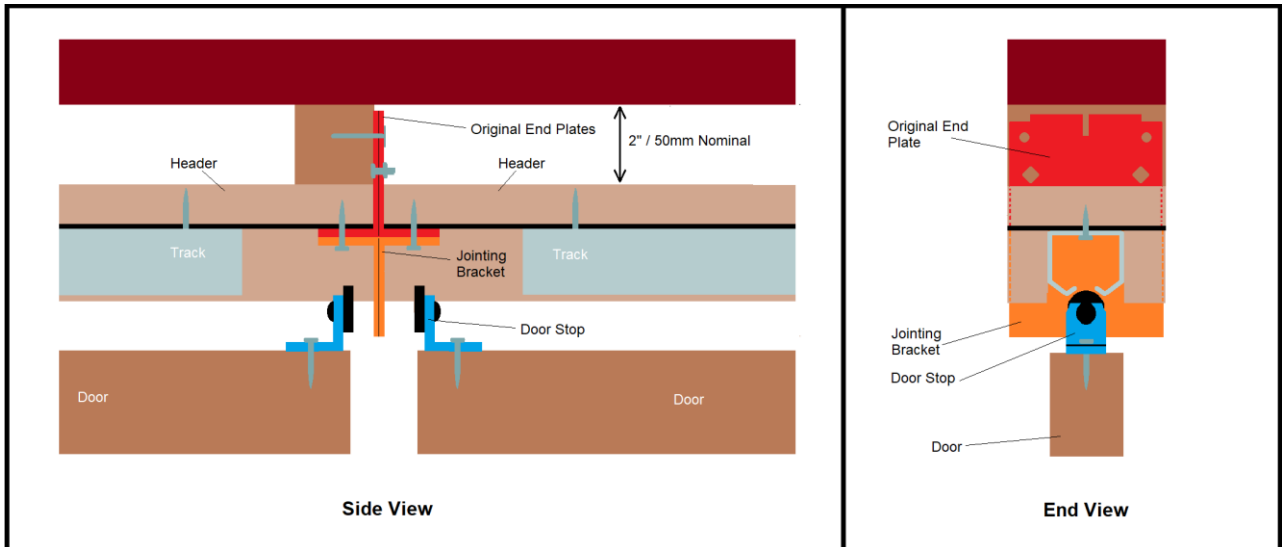

- Turn it upside down secure back in place with 1 of the kit plates in position above it.
- On one side of the centre line of the opening secure a block that measures approximately 50 x 50 x 82mm
- Bolt the 2 headers together with the 2 bolts provided through the original brackets
- Position the double header in place by hooking the end plates over the support nails
- Level the header, insert the support nails into the central timber packer, then the side timbers
- Drive in the remaining nails through the plates into the timbers ensuring the header is kept level.
- When the doors have been hung, position one door stop on each door so that the doors stop against the jointing plates with the doors fully closed against each other.

Step 4 : Installing Support Studs

- Cut down the steel wrapped studs to the required height (if necessary).
- Once cut the headers need to finish flush with the top of the header to ensure the maximum amount of support.
- Pre-drill the header fixing holes in the top of the studs, the top wooden header board is 18mm this so drill the holes around 9mm from the top of the stud.
- Mark or use chalk lines on the floor in line with the header (right image).
- Align the stud foot brackets on the floor centrally between the two lines, the first should line up against the nailers at the side of the opening. The second and third are then evenly spaced (right image) in the gap.

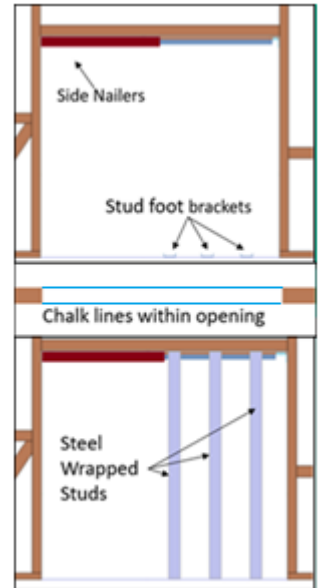

- Fit the steel wrapped studs (timber outwards) to the foot brackets (see below), then attach them to the header (right image).

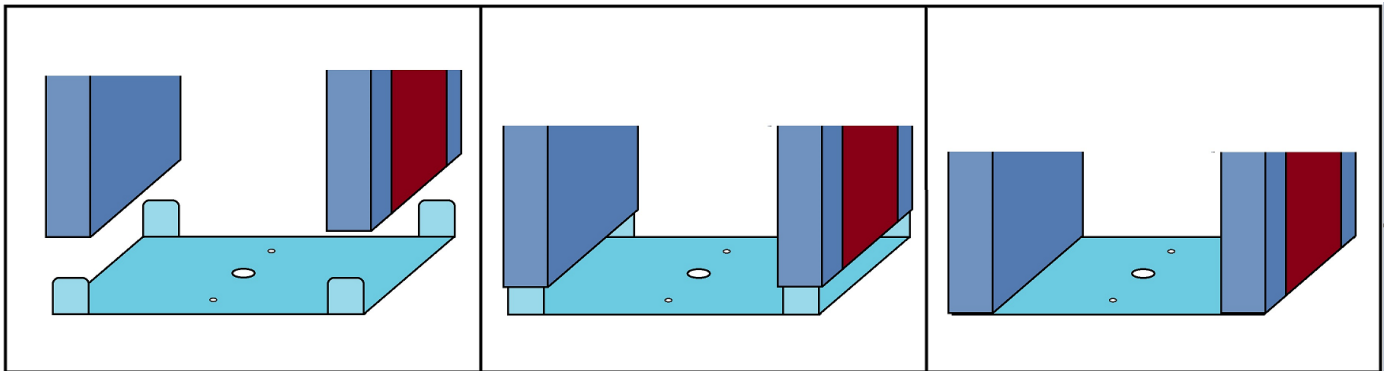

Section Showing Timber Door Installation

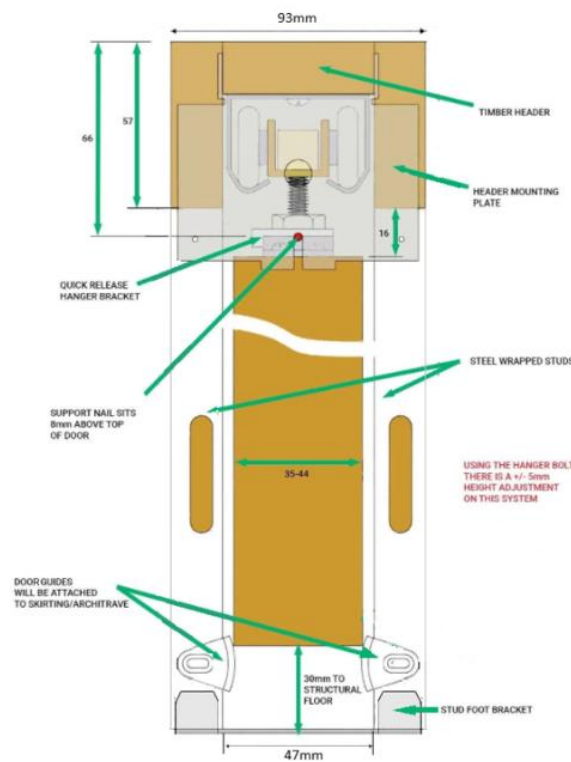

Step 5 : Install The Rubber Buffer

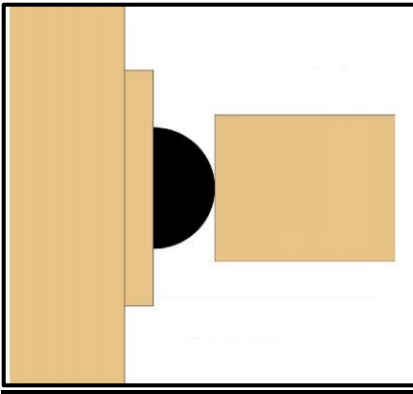

- Position the rubber buffer at the back of the pocket, approximately halfway up the upright.
- This can be packed if necessary to position the door in the correct position when the door is open.



The buffer can be replaced if desired with a pocket door hold open piston (optional extra), this is an optional extra and is available to purchase separately.

- Suitable for most pocket doors, the magnetic piston catches the keep when the door is in the open position enabling the door to stay open.
- A push gently releases the catch so the handles on the face of the door can be reached, to close the door.

Step 6 : Fitting Wall Surface

Insert the timber packer (approximately 52 x 25mm - not supplied) between all three pairs of the steel wrapped studs (the studs shouldn't to bend or be distorted in anyway)

IMPORTANT – THE PACKER SHOULD FIT BETWEEN ALL THREE ROWS OF STUDS FOR THE LENGTH

Apply the wall facing of choice (Plasterboard, MDF, Plywood etc.)

Secure the facing with screws of an appropriate length (studs are 18mm thick)

The screws cannot be allowed to pass through the studs as they could damage the surface of the door whilst it is in the pocket.



- It should be noted that there is a slight flex in the pockets walls if thin plasterboard is used.
- If there is a probability of side loading on the wall of the pocket consideration should be given to using plywood or MDF as a stronger alternative or use thicker plasterboard.
- There is a 4mm difference in height between the nailers and the support studs, this should be planned for when working out your wall surface materials.
- Once the wall surface is completed remove the packer from the pocket.

Step 7 : Door Installation

- Unclip the white retaining clip on the hanger mounting plates
- Remove the post that the wheels are attached to from the mounting plates.

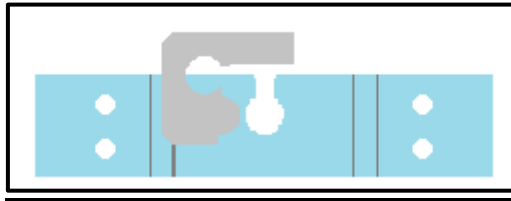

- Position the mounting plates centrally along the centre line of the door and 90mm in from the edge at each end

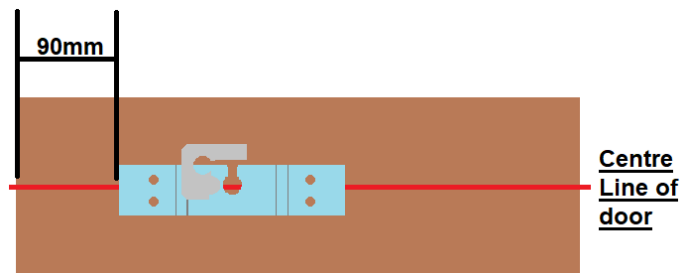

- The drilling of pilot holes is advisable as the screw threads are quite large.
- Ensure that the retaining clip is on the same side for both mounting plates (this will be important when hanging the door).
- Adjust the post in the hangers so the end of the bolt sits level with the top of the brass receiver in the wheeled carriage. Insert the wheeled hangers into the track, facing opposite directions as shown below.

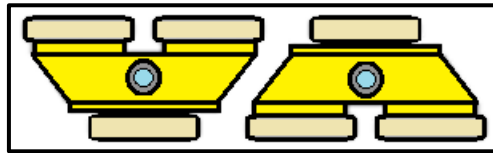

- Position the rear edge of the door between the 1st pair of the steel wrapped studs.
- Use either packers or a door lifter to support the door whilst you locate the hanger plate onto the wheeled hanger post.
- Once in position shut the white retaining clip around the carriage post and press it firmly into place to lock it into position.
- Repeat the process for the front wheeled hanger.
- ***Make sure you are careful when sliding the door into position to attach the front carriage, as the door guides are not yet in position to protect the door.***
- To remove the door for redecoration or replacement reverse the process of fitting the door, carefully unclipping the retaining clips and removing the door from the cavity.
- Any skirting boards that are required can now be fitted, making sure that the fixings do not protrude into the pocket and contact the door surface.

Optional Stage – Soft Closer (optional extra not part of standard kit)

- Measuring from the edge of the door furthest from pocket when closed
- Soft closer is positioned 40mm behind the first mounting bracket.
- *Please note for doors between 686-734mm position the soft closer up against the mounting plate and the catch is fitted 279mm from the door jamb.*
- The body of the soft closer should be 4mm in from the face of the door.
- The catch or trigger plate should be notched into the header 319mm from the jamb.

Softclose Installation For Pocket Door Kit

Our PD1 & PD2 kits can accommodate a Softclose Device and the details are shown here.

Please note that the Catch for the Softclose has to be notched into the Timber Header as shown.

Ensure once Catch is fitted that it does not foul the Hanger Plates as they pass.

The plan view gives dimensions for positioning both Softclose and Catch. These dimensions are calculated when Door is in the closed position and tight against the Door Jamb.

Test once installed and adjust Catch if required. Only when happy should you then line the opening. Ensure any architraves are removable should further adjustment or repair be required in the future.

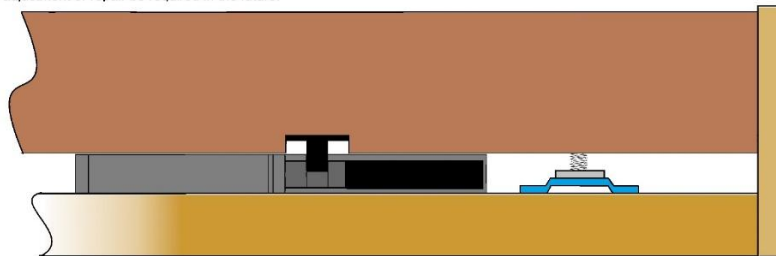
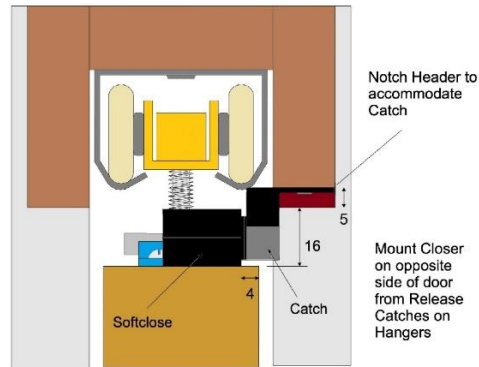

Plan View Showing Top Of Door & Hardware Positioning

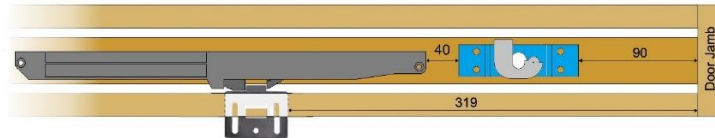

Simultaneous Door Opening Kit

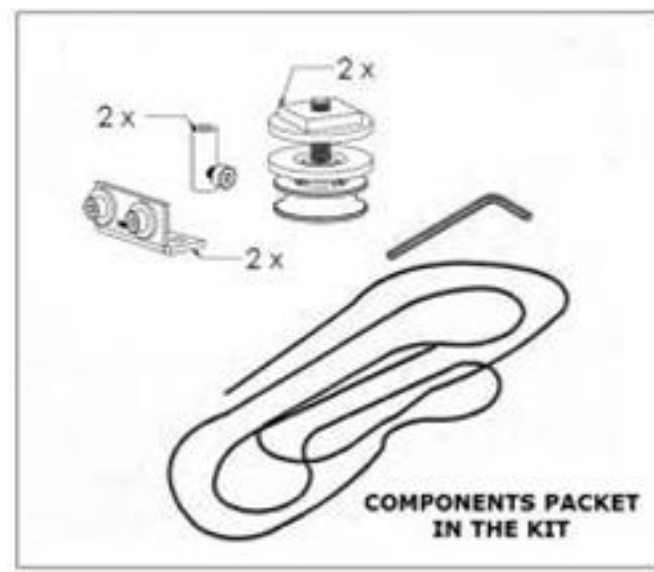

1. Fix the tensioning plate (A) in the middle of the door on the front edge, one should face the front of the door and the other the rear of the door.

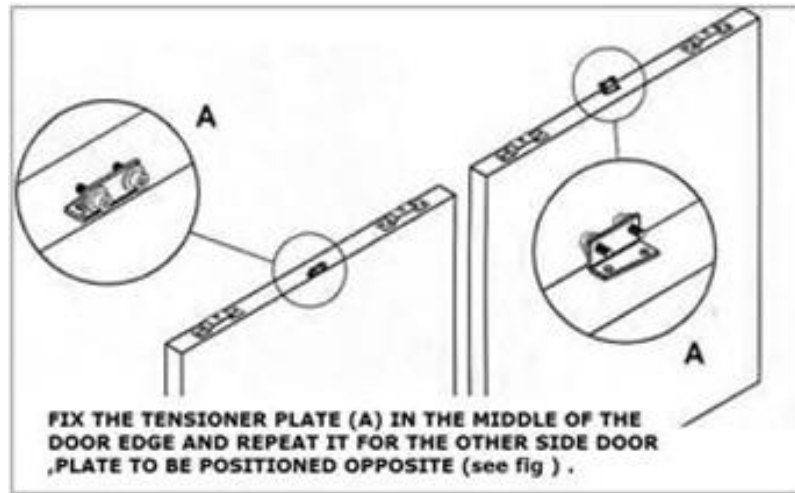

2. Fix the pulleys at each end of the tracks in positions B and E as shown below.

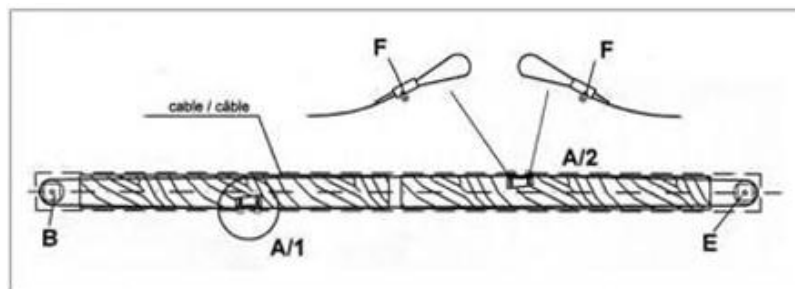

3. Close both doors and adjust the length of the cable, insert any excess cable into the connector as shown above, then tighten it up with the allen key and socket screw.
4. Loosen both screws on A1 and place one cable loop around each and tighten the screw down so that the washer traps the cable loop against the plate. Loosen both the screws on A2 and run the cable un both screws and tighten the screws back down, to trap the cable between the washers and the plate.

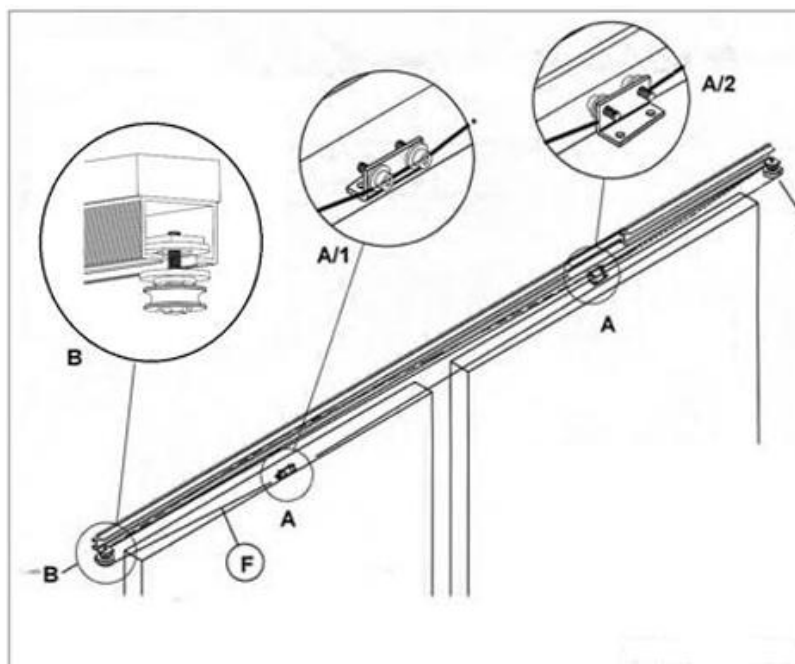

5. Test the doors are aligned correctly and open and close fully when one of the doors is moved.

Door Jambs

- The door jambs are not supplied due to the kits being adjustable, it is recommended that these are constructed and fitted to be removable. This will be essential should the door need to be taken out of the pocket for any reason.



- The rough layout for a cutting template for a 115mm wide door lining kit is shown below. Dimension "C" is equal to the thickness of the lining kit, and D is half the width of B.

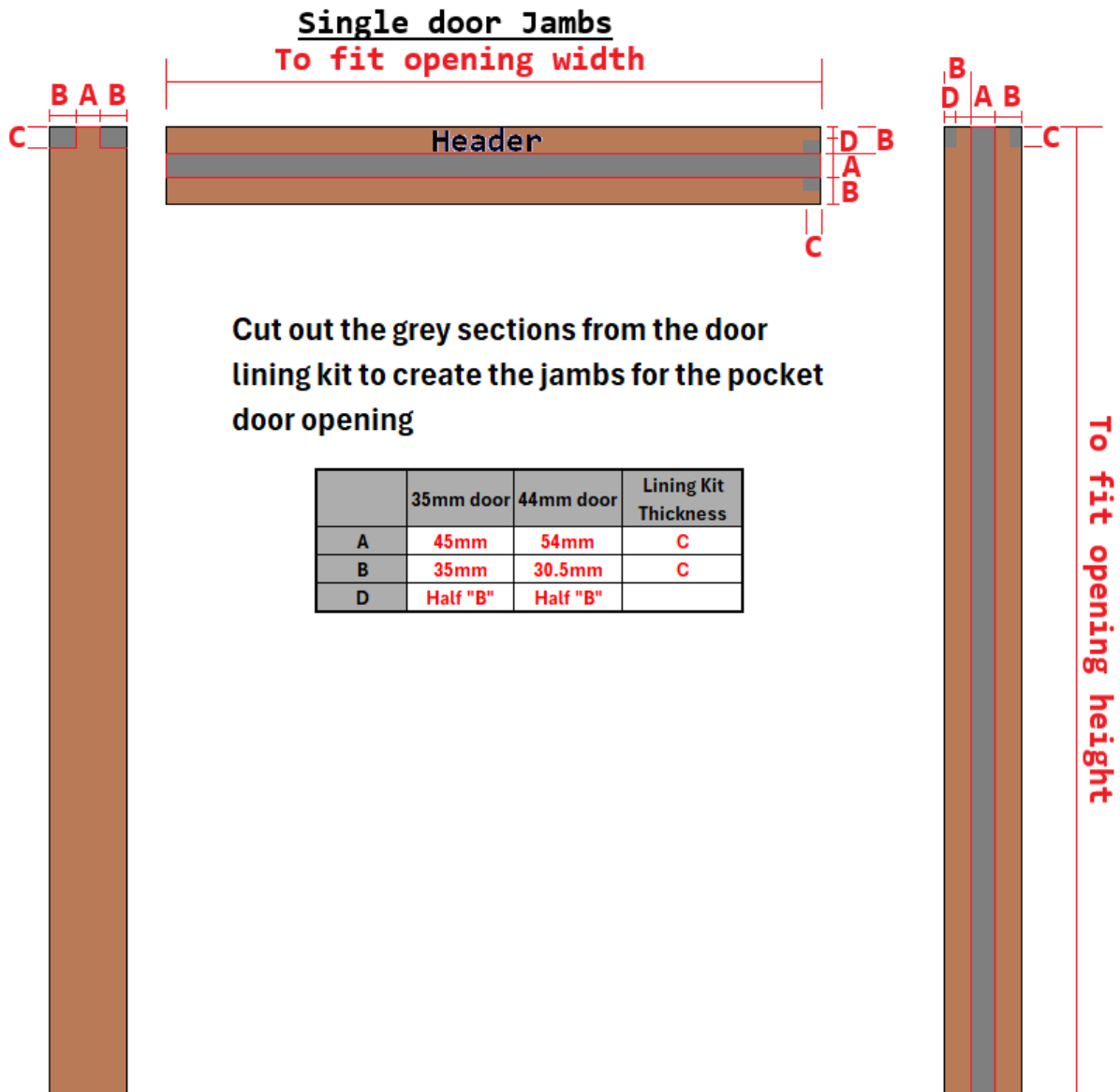

Double Door Jams
To fit opening width

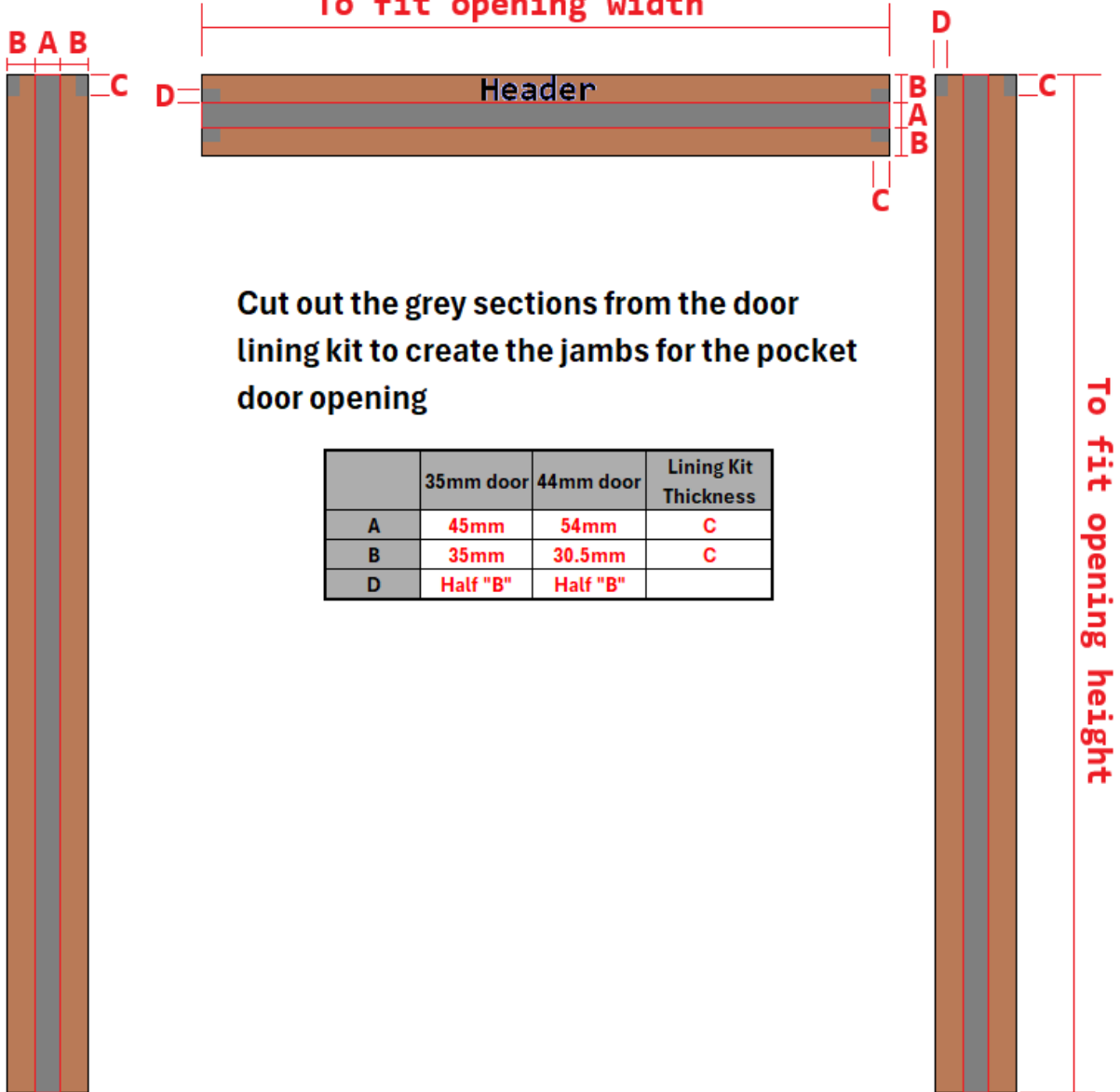

- The newly cut jambs can then be assembled in the opening as shown below and fixed within the opening.

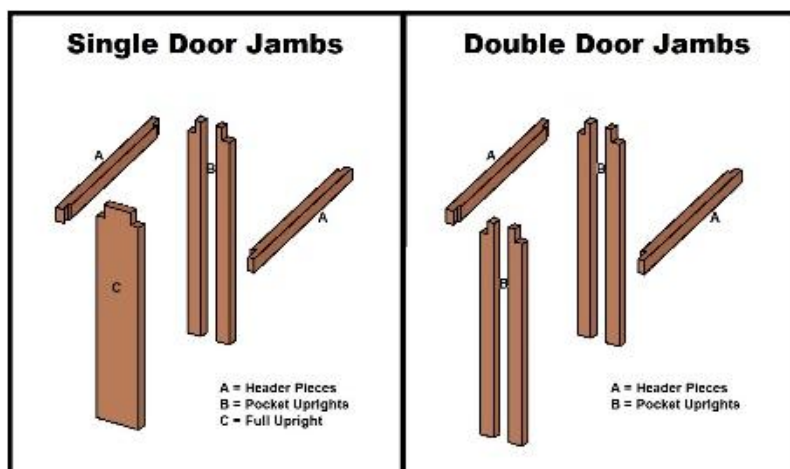

- Fix any architrave that is required around the doorway.

- Secure the door guides to the frame, for 44mm thick doors these may need to be recessed into the trim.

